

**SPECIFICATIONS**

AO Medium		TeO2
Acoustic Velocity		4.2 mm/μs
Active Aperture*		0.6 mm 'H'
Center Frequency (Fc)		110 MHz
RF Bandwidth	24 MHz @	-10 dB Return Loss
Input Impedance		50 Ohms Nominal
VSWR @ Fc		1.3:1 Max
Wavelength		442-633 nm
Insertion Loss		4 % Max
Reflectivity per Surface		1 % Max
Anti-Reflection Coating		MIL-C-48497
Optical Power Density		250 W/mm <sup>2</sup>
Contrast Ratio		1000:1 Min
Polarization		90 ° To Mounting Plane

**PERFORMANCE VS WAVELENGTH**

Wavelength (nm)	442	488	515	633
Saturation RF Power (W)	0.29	0.39	0.43	0.65
Bragg Angle (mr)	5.8	6.4	6.7	8.3
Beam Separation	11.6	12.8	13.4	16.6

**PERFORMANCE VS BEAM DIAMETER**

Beam Diameter (μm)	110	130	200	500
at Wavelength (nm)	633	633	633	633
Diffraction Efficiency (%)	70	75	80	83
Rise Time (nsec)	25	28	39	86
Modulation Bandwidth	28	24	15.8	6.3
Beam Ellipticity	20	10	5	1

**For Reference Only**

\*Active Aperture: Aperture over which performance specifications apply.

**Outline Drawing: Package 3110-140**

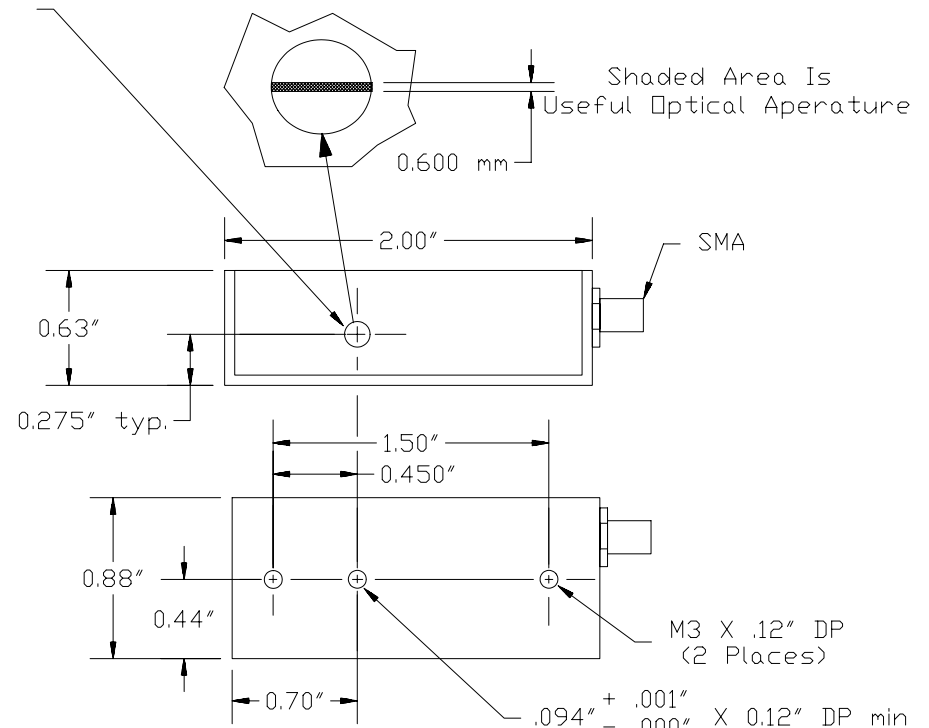

**Notes:**  
Surface Quality is 10-5 S/D over useful Optical Aperture

THIS DOCUMENT IS THE PROPERTY OF CRYSTAL TECHNOLOGY, INC. IT IS NOT TO BE REPRODUCED OR DISCLOSED IN WHOLE OR IN PART OTHER THAN BY EMPLOYEES CRYSTAL TECHNOLOGY AND ITS CONTRACTED REPRESENTATIVES AND DISTRIBUTORS. ANY EXCEPTION REQUIRES THE WRITTEN CONSENT OF AN AUTHORIZED REPRESENTATIVE OF CRYSTAL TECHNOLOGY.

TOLERANCES: .XX ± .01 .XXX ± .005	DR	A. Campi 6/17/2002	<b>Crystal Technology, Inc.</b> DESCRIPTION: <b>AOMO 3110-140</b>
MATERIAL:	CHK		
FINISH:	APP		
	APP		PART NUMBER: <b>97-00811-01</b>
			REV: <b>A</b>
			SHEET 1 OF 1